

4SR-F®

RODETES FLOTANTES (PATENTADO)



Electrobombas sumergidas de 4"

 Agua limpia
(Contenido de arena
máximo 200 g/m³)

 Uso doméstico

 Uso civil

 Uso industrial

 Uso agrícola

CAMPO DE PRESTACIONES

- Caudal hasta **240 l/min (14.4 m³/h)**
- Altura manométrica hasta **447 m**

LÍMITES DE USO

- Temperatura máxima del fluido hasta **+35 °C**
- Contenido de arena máximo **200 g/m³**
- Profundidad de uso bajo el nivel del agua:
200 m con motores 4PD, **100 m** con motores 4PS
- Profundidad de uso bajo el nivel del agua **200 m**
- Funcionamiento:
 - **en vertical**
 - **en horizontal** con los siguientes límites:
4SR10G - 4SR13G - 4SR25G hasta **16 etapas**
4SR33G - 4SR45G hasta **9 etapas**
- Arranques/hora: **20** a intervalos regulares
- Flujo de enfriamiento motor mínimo **8 cm/s**
- Funcionamiento continuo **S1**

USOS E INSTALACIONES

Electrobombas sumergibles de 4" indicadas para el bombeo de aguas limpias, utilizables en múltiples aplicaciones, como, por ejemplo, el suministro de agua doméstica, riego, invernaderos y sierras, instalaciones hídricas para comunidades y presurización.

Los componentes hidráulicos, acoplados a un motor eléctrico de alto rendimiento, hacen que la electrobomba 4SR sea extremadamente eficiente en la categoría.

Ahorro económico en el uso del agua gracias al elevado rendimiento y al consiguiente reducido consumo eléctrico. La construcción con impulsores flotantes permite el bombeo de agua con un contenido de arena hasta **200 g/m³**.

La instalación es posible en posición vertical u horizontal.

PATENTES

- **Patent n° EP3123031, EP2419642**

EJECUCIÓN Y NORMAS DE SEGURIDAD

MOTOR ELÉCTRICO

Trifásica 380 V - 60 Hz - Monofásica 220 V - 60 Hz

- **Condensador incluido en el embalaje**

Cable de alimentación de:

- **2 m** para potencias de 0.37 a 2.2 kW
- **3.6 m** para potencias de 3 a 7.5 kW.

EN 60335-1
IEC 60335-1
CEI 61-150

EN 60034-1
IEC 60034-1
CEI 2-3



EJECUCIÓN BAJO PEDIDO

- Cuerpo bomba con bocas roscadas ISO 228/1
- Otros voltajes
- Kit camisa de enfriamiento completo con filtro y soportes; recomendado para potencias desde 2.2 kW hasta 7.5 kW



CAMISA DE ENFRIAMIENTO



CURVAS Y DATOS DE PRESTACIONES

60 Hz n = 3450 min⁻¹

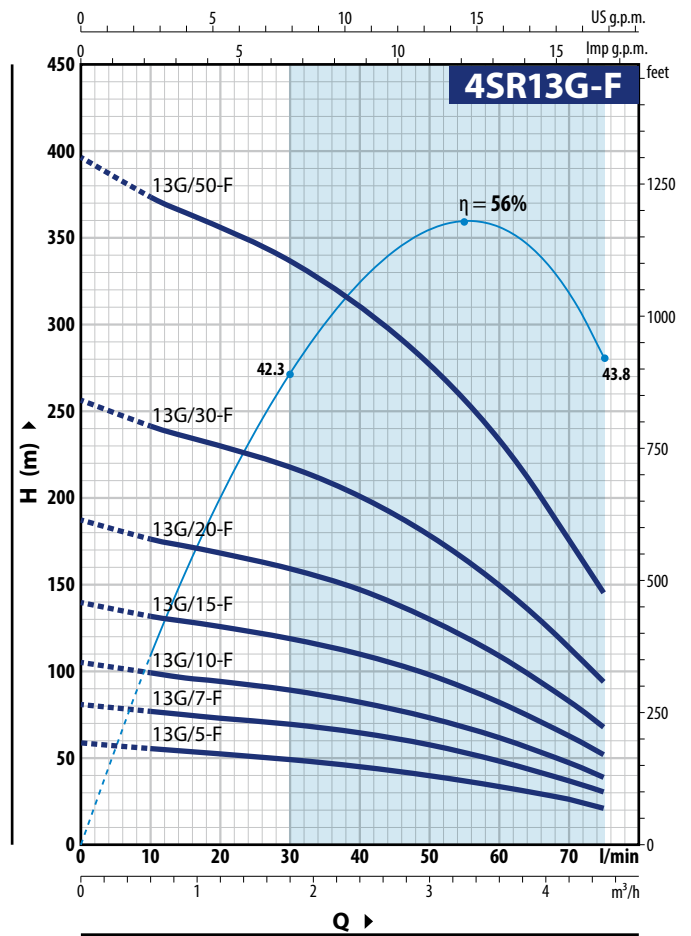
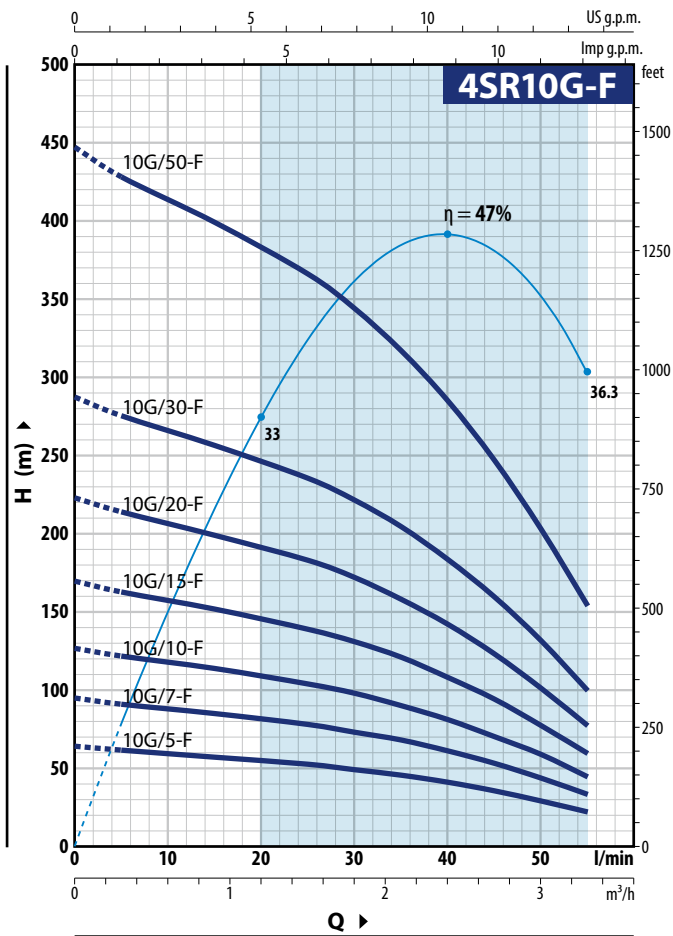

4SR10G-F

MODELO		N. ETAPAS	POTENCIA (P ₂)		Q	H metros										
Monofásica	Trifásica		kW	HP		0	0.3	0.6	0.9	1.2	1.5	1.8	2.4	3.0	3.3	
4SRm 10G/5 -F *	4SR 10G/5 -F *	6	0.37	0.50	0	0	5	10	15	20	25	30	40	50	55	
4SRm 10G/7 -F *	4SR 10G/7 -F *	9	0.55	0.75	64	61.5	59	57	55	52.5	49	41	29	22		
4SRm 10G/10 -F *	4SR 10G/10 -F *	12	0.75	1	96	92	89	86	82	78	74	61	43.5	33		
4SRm 10G/15 -F *	4SR 10G/15 -F *	16	1.1	1.5	128	123	118	114	110	105	98	82	58.5	44		
4SRm 10G/20 -F *	4SR 10G/20 -F *	21	1.5	2	170	163	158	152	146	140	131	109	78	59		
4SRm 10G/30-F	4SR 10G/30-F *	27	2.2	3	224	214	207	200	192	183	172	143	102	77		
-	4SR 10G/50-F *	42	3.7	5	288	276	266	257	247	235	221	184	131	99		
					447	429	414	399	384	366	344	286	204	155		

4SR13G-F

MODELO		N. ETAPAS	POTENCIA (P ₂)		Q	H metros									
Monofásica	Trifásica		kW	HP		0	0.6	0.9	1.2	1.8	2.4	3.0	3.6	4.2	4.5
4SRm 13G/5 -F	4SR 13G/5 -F	5	0.37	0.50	0	0	10	15	20	30	40	50	60	70	75
4SRm 13G/7 -F	4SR 13G/7 -F	7	0.55	0.75	58,5	55	54	52,5	49,5	46	41	34	26	21,5	
4SRm 13G/10-F	4SR 13G/10-F	9	0.75	1	82	77	75	74	69,5	64,5	57,5	48	36,5	30	
4SRm 13G/15-F	4SR 13G/15-F	12	1.1	1.5	105	99	97	95	89	83	74	61,5	47	38,5	
4SRm 13G/20-F	4SR 13G/20-F	16	1.5	2	140	132	129	126	119	110	98	82	62,5	51,5	
4SRm 13G/30-F	4SR 13G/30-F	22	2.2	3	187	176	172	168	159	147	131	110	83	68,5	
-	4SR 13G/50-F	34	3.7	5	257	242	237	231	219	202	180	151	114	94	
					398	375	366	357	338	313	278	233	177	145	

Q = Caudal H = Altura manométrica total

* Modelos solicitados bajo pedido

Tolerancia de las curvas de prestación según EN ISO 9906 Grado 3B.

CURVAS Y DATOS DE PRESTACIONES

60 Hz n = 3450 min⁻¹

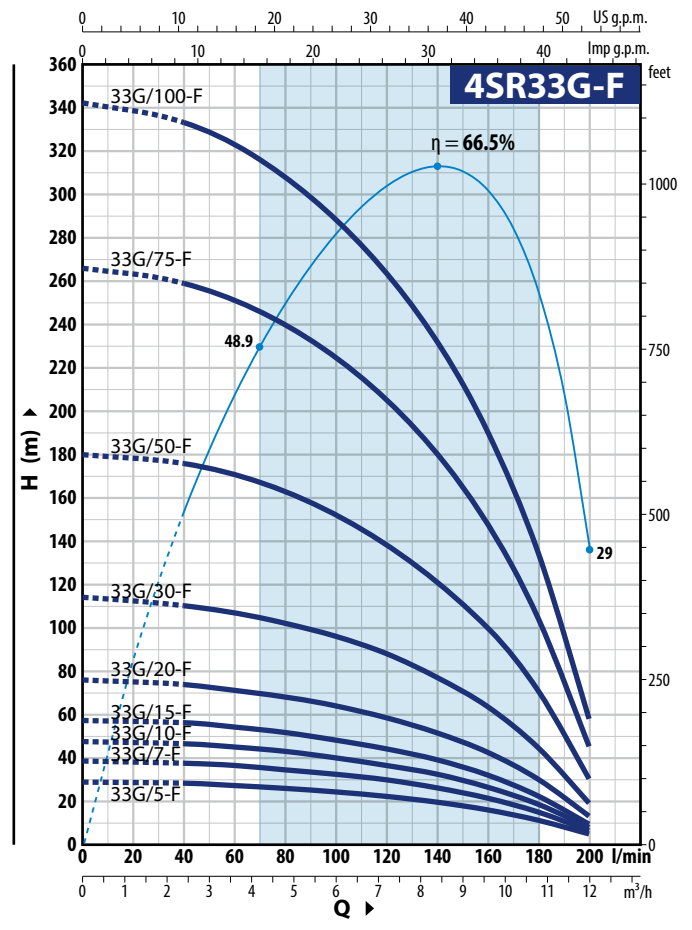
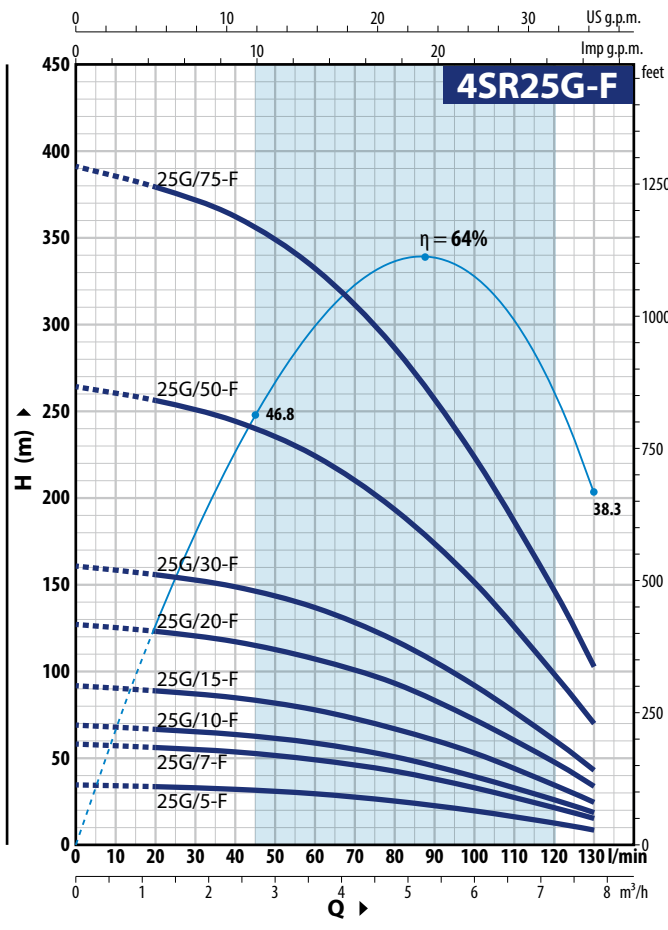

4SR25G-F

MODELO		N. ETAPAS	POTENCIA (P ₂)		Q m³/h l/min	H metros							
Monofásica	Trifásica		kW	HP		0	1.2	2.4	3.6	4.8	6.0	7.2	7.8
4SRm 25G/5 -F	4SR 25G/5 -F	3	0.37	0.50	0	34.5	33.5	32	29.5	25.4	19.8	13	9
4SRm 25G/7 -F	4SR 25G/7 -F	5	0.55	0.75	20	58	56	53.5	49	42.5	33	21.6	15.5
4SRm 25G/10-F	4SR 25G/10-F	6	0.75	1	40	69.5	67	64	59	51	39.5	26	18.5
4SRm 25G/15-F	4SR 25G/15-F	8	1.1	1.5	60	92	90	85	78	67.5	53	34.5	24.5
4SRm 25G/20-F	4SR 25G/20-F	11	1.5	2	80	127	123	118	108	93	73	47.5	33.5
4SRm 25G/30-F *	4SR 25G/30-F *	14	2.2	3	100	162	157	150	137	118	93	60.5	43
-	4SR 25G/50-F	23	3.7	5	120	266	258	246	226	195	152	100	70.5
-	4SR 25G/75-F *	34	5.5	7.5	130	393	381	363	333	288	225	147	104

4SR33G-F

MODELO		N. ETAPAS	POTENCIA (P ₂)		Q m³/h l/min	H metros									
Monofásica	Trifásica		kW	HP		0	2.4	3.6	4.8	6.0	7.2	8.4	9.6	10.8	12.0
4SRm 33G/5 -F *	4SR 33G/5 -F *	3	0.37	0.50	0	28.5	28	26.8	25.7	24.1	22.1	19.4	15.9	11.1	5
4SRm 33G/7 -F *	4SR 33G/7 -F *	4	0.55	0.75	40	38	37	36	34	32	29.5	25.9	21.2	14.9	6.5
4SRm 33G/10-F	4SR 33G/10-F	5	0.75	1	60	47.5	46.5	44.5	43	40	37	32.5	26.5	18.6	8
4SRm 33G/15-F	4SR 33G/15-F	6	1.1	1.5	80	57	55.5	53.5	51.5	48	44	39	32	22.3	9.5
4SRm 33G/20-F	4SR 33G/20-F	8	1.5	2	100	76	74	72	68.5	64.5	59	52	42.5	29.5	13
4SRm 33G/30-F	4SR 33G/30-F	12	2.2	3	120	114	111	107	103	96	88	78	63.5	44.5	19
-	4SR 33G/50-F *	19	3.7	5	140	181	176	170	162	153	140	123	101	70.5	30.5
-	4SR 33G/75-F *	28	5.5	7.5	160	267	259	251	239	225	206	182	148	104	45
-	4SR 33G/100-F *	36	7.5	10	180	343	333	322	308	289	265	233	191	134	57.5

Q = Caudal H = Altura manométrica total

* Modelos solicitados bajo pedido

Tolerancia de las curvas de prestación según EN ISO 9906 Grado 3B.

CURVAS Y DATOS DE PRESTACIONES

60 Hz n = 3450 min⁻¹

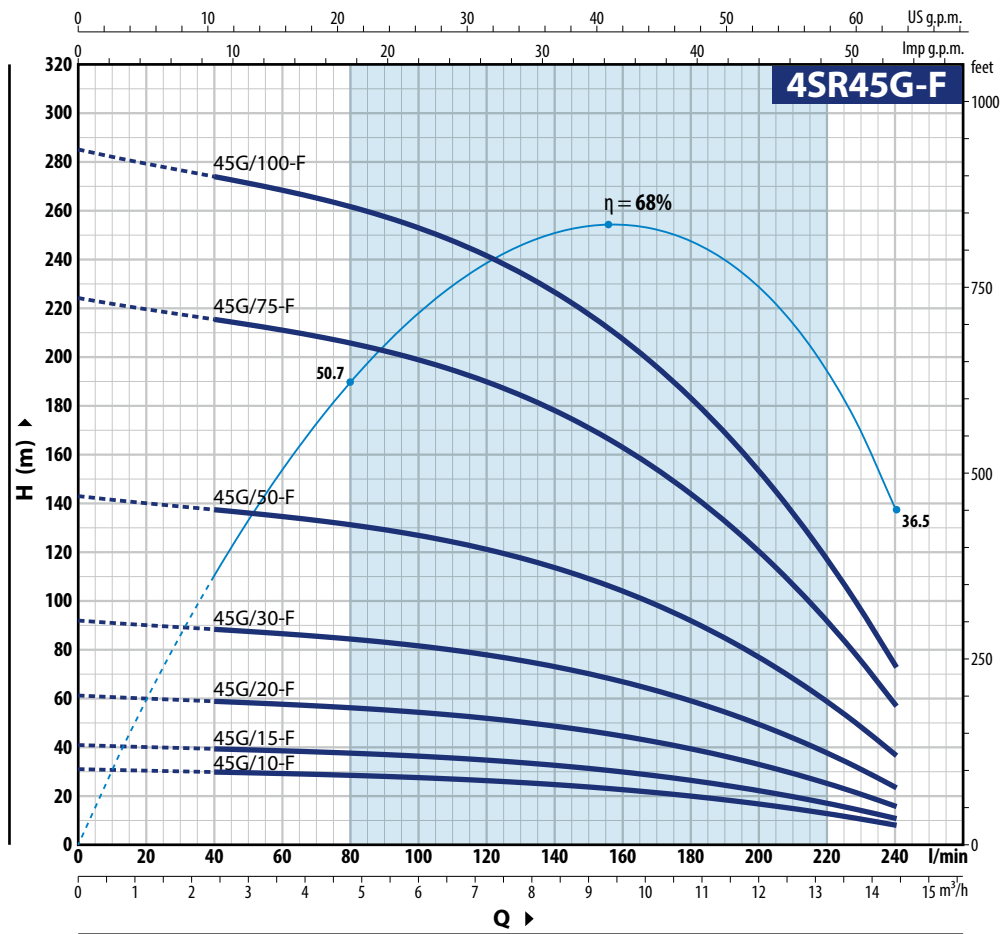

4SR45G-F

MODELO		N. ETAPAS	POTENCIA (P ₂)		Q m ³ /h l/min	0	2.4	4.8	7.2	9.6	12.0	14.4
Monofásica	Trifásica		kW	HP		0	40	80	120	160	200	240
4SRm 45G/10 -F *	4SR 45G/10 -F *	3	0.75	1	H metros	30.5	29.5	28	25.9	22.2	16.4	7.5
4SRm 45G/15 -F *	4SR 45G/15 -F *	4	1.1	1.5		41	39	37.5	34.5	29.5	21.8	10.5
4SRm 45G/20-F	4SR 45G/20 -F	6	1.5	2		61	59	56	52	44.5	32.5	15.5
4SRm 45G/30-F	4SR 45G/30 -F	9	2.2	3		92	88	84	78	66.5	49	23
-	4SR 45G/50 -F	14	3.7	5		143	137	131	121	104	76	36
-	4SR 45G/75 -F	22	5.5	7.5		224	216	206	190	163	120	57
-	4SR 45G/100-F *	28	7.5	10		286	274	262	242	207	153	72.5

Q = Caudal H = Altura manométrica total

Tolerancia de las curvas de prestación según EN ISO 9906 Grado 3B.

* Modelos solicitados bajo pedido

POS. COMPONENTE

CARACTERÍSTICAS CONSTRUCTIVAS

1	CUERPO DE IMPULSION	Acero inoxidable micro fundido AISI 304 dotado de boca de impulsión roscada NPT ANSI B 1.20.1
2	VÁLVULA DE RETENCIÓN	Acero inoxidable AISI 304
3	SOPORTE	Acero inoxidable AISI 304, dimensiones según norma NEMA
4	RODETE	Delrin
5	DIFUSOR	Noryl
6	CAJA PORTA DIFUSOR	Acero inoxidable AISI 304
7	EJE BOMBA	Acero inoxidable AISI 304
8	RODAMIENTOS BOMBA	Parte fija en tecnopolímero especial y parte rotatoria en acero inoxidable AISI 316 revestida de óxido de cromo para resistir a la arena
9	CASQUILLO	Acero inoxidable AISI 316L hasta 2.2 kW; acero inoxidable AISI 304 para potencias superiores
10	FILTRO	Acero inoxidable AISI 304
11	PROTECTOR CABLE	Acero inoxidable AISI 304
12	MOTOR 4"	4PD = motor en baño de aceite rebobinable

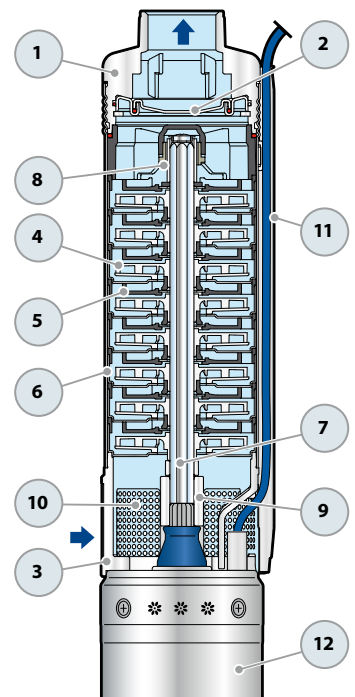

EJEMPLO DE INSTALACIÓN

- 1) Electrobomba sumergida
- 2) Cintas para fijar el cable de alimentación
- 3) Sondas control nivel contra la marcha en seco
- 4) Soporte y cable de anclaje
- 5) Manómetro
- 6) Válvula de retención
- 7) Válvula de compuerta del caudal
- 8) Cable de alimentación eléctrica
- 9) Cuadro eléctrico
- 10) Depósito autoclave
- 11) Presóstato
- 12) Electro-válvula/electro-compresor

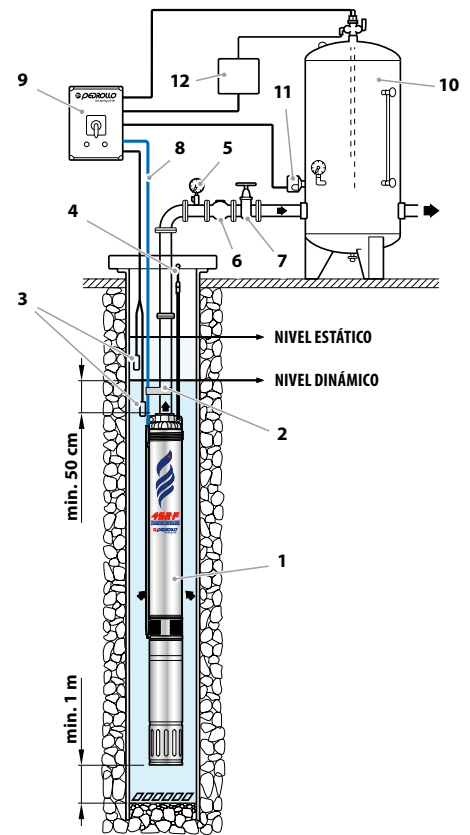
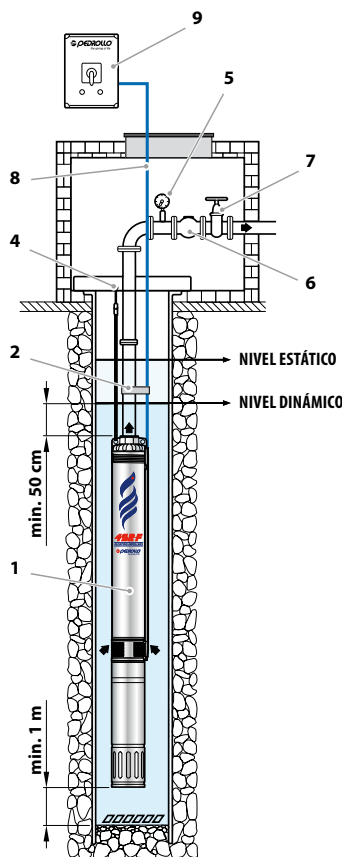

La instalación de las electrobombas **4SR** es apta para pozos con un diámetro no inferior a 4" (100 mm). La electrobomba sumergida se baja al pozo mediante el tubo de impulsión hasta una profundidad tal que garantice su total inmersión (min. 50 cm y por lo menos 1 metro desde el fondo del pozo) incluso mientras funciona, cuando se aprecia una disminución del líquido en el pozo. Cuando la electrobomba sumergida se instala en un pozo, se aconseja asegurarla con un cable de acero inoxidable para conectarla a los específicos enganches de la boca de impulsión.

DIMENSIONES Y PESOS (Bombas combinadas con motores sumergibles 4PD)

MODELO	DN	N. ETAPAS	DIMENSIONES mm			kg
			h1	h2	h3	
Monofásica						
4SRm 10G/5 -F - PD	1 1/4" NPT	6	283	331	614	10.8
4SRm 10G/7 -F - PD		9	343	331	674	11.2
4SRm 10G/10 -F - PD		12	402	356	758	13.0
4SRm 10G/15 -F - PD		16	508	396	904	16.0
4SRm 10G/20 -F - PD		21	608	437	1045	19.4
4SRm 10G/30 -F - PD		27	727	492	1219	23.7
4SRm 13G/5 -F - PD		5	263	331	594	10.6
4SRm 13G/7 -F - PD		7	303	331	634	10.9
4SRm 13G/10 -F - PD		9	343	356	699	12.5
4SRm 13G/15 -F - PD		12	402	396	798	15.0
4SRm 13G/20 -F - PD		16	508	437	945	17.9
4SRm 13G/30 -F - PD		22	627	492	1119	22.2
4SRm 25G/5 -F - PD		3	238	331	569	10.2
4SRm 25G/7 -F - PD		5	288	331	619	10.5
4SRm 25G/10 -F - PD		6	313	356	669	12.1
4SRm 25G/15 -F - PD		8	363	396	759	14.3
4SRm 25G/20 -F - PD		11	437	437	874	16.9
4SRm 25G/30 -F - PD		14	538	492	1030	20.8
4SRm 33G/5 -F - PD		3	258	331	589	10.2
4SRm 33G/7 -F - PD		4	289	331	620	10.4
4SRm 33G/10 -F - PD		5	320	356	676	12.1
4SRm 33G/15 -F - PD		6	352	396	748	14.0
4SRm 33G/20 -F - PD		8	415	437	852	16.3
4SRm 33G/30 -F - PD		12	566	492	1058	20.5
4SRm 45G/10 -F - PD		3	258	356	614	11.5
4SRm 45G/15 -F - PD		4	289	396	685	13.5
4SRm 45G/20 -F - PD		6	352	437	789	15.5
4SRm 45G/30 -F - PD	9	446	492	938	19.8	

MODELO	DN	N. ETAPAS	DIMENSIONES mm			kg
			h1	h2	h3	
Trifásica						
4SR 10G/5 -F - PD	1 1/4" NPT	6	283	331	614	10.8
4SR 10G/7 -F - PD		9	343	331	674	11.2
4SR 10G/10 -F - PD		12	402	356	758	13.0
4SR 10G/15 -F - PD		16	508	371	879	15.2
4SR 10G/20 -F - PD		21	608	396	1004	17.9
4SR 10G/30 -F - PD		27	727	437	1164	20.5
4SR 10G/50 -F - PD		42	1123	505	1628	25.6
4SR 13G/5 -F - PD		5	263	331	594	10.6
4SR 13G/7 -F - PD		7	303	331	634	10.9
4SR 13G/10 -F - PD		9	343	356	699	12.5
4SR 13G/15 -F - PD		12	402	371	774	14.2
4SR 13G/20 -F - PD		16	508	396	904	16.4
4SR 13G/30 -F - PD		22	627	437	1064	19.0
4SR 13G/50 -F - PD		34	964	505	1469	29.2
4SR 25G/5 -F - PD		3	238	331	569	10.2
4SR 25G/7 -F - PD		5	288	331	619	10.5
4SR 25G/10 -F - PD		6	313	356	669	12.1
4SR 25G/15 -F - PD		8	363	371	734	13.5
4SR 25G/20 -F - PD		11	437	396	833	15.4
4SR 25G/30 -F - PD		14	538	437	975	17.6
4SR 25G/50 -F - PD		23	762	505	1267	24.6
4SR 25G/75 -F - PD		34	1134	589	1723	34.5
4SR 33G/5 -F - PD		3	258	331	589	10.2
4SR 33G/7 -F - PD		4	289	331	620	10.4
4SR 33G/10 -F - PD		5	320	356	676	12.1
4SR 33G/15 -F - PD		6	352	371	723	13.2
4SR 33G/20 -F - PD		8	415	396	811	14.8
4SR 33G/30 -F - PD	12	566	437	1003	17.3	
4SR 33G/50 -F - PD	19	786	505	1291	24.6	
4SR 33G/75 -F - PD	28	1095	589	1684	32.5	
4SR 33G/100 -F - PD	36	1418	800	2218	47.0	
4SR 45G/10 -F - PD	3	258	356	614	11.5	
4SR 45G/15 -F - PD	4	289	371	660	12.6	
4SR 45G/20 -F - PD	6	352	396	748	14.0	
4SR 45G/30 -F - PD	9	446	437	883	16.6	
4SR 45G/50 -F - PD	14	629	505	1134	22.4	
4SR 45G/75 -F - PD	22	907	589	1496	29.9	
4SR 45G/100 -F - PD	28	1095	800	1895	41.1	

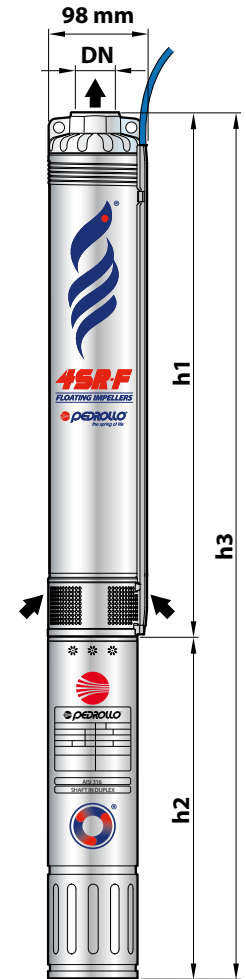

DIMENSIONES Y PESOS (solo hidráulica)

MODELO	DN	N. ETAPAS	DIMENSIONES mm		kg
			h1	h	
4SR 10G/5 -F - HYD	1 1/4" NPT	6	283	286	3.5
4SR 10G/7 -F - HYD		9	343	346	3.9
4SR 10G/10 -F - HYD		12	402	405	4.4
4SR 10G/15 -F - HYD		16	508	511	5.5
4SR 10G/20 -F - HYD		21	608	611	7.4
4SR 10G/30 -F - HYD		27	727	730	8.5
4SR 10G/50 -F - HYD		42	1123	1126	8.8
4SR 13G/5 -F - HYD		5	263	266	3.3
4SR 13G/7 -F - HYD		7	303	306	3.6
4SR 13G/10 -F - HYD		9	343	346	3.9
4SR 13G/15 -F - HYD		12	402	405	4.7
4SR 13G/20 -F - HYD		16	508	511	5.8
4SR 13G/30 -F - HYD		22	627	630	7.0
4SR 13G/50 -F - HYD		34	964	967	12.9
4SR 25G/5 -F - HYD		3	238	241	3.0
4SR 25G/7 -F - HYD		5	288	291	3.3
4SR 25G/10 -F - HYD		6	313	316	3.5
4SR 25G/15 -F - HYD		8	363	366	4.0
4SR 25G/20 -F - HYD		11	437	440	4.8
4SR 25G/30 -F - HYD		14	538	541	5.6
4SR 25G/50 -F - HYD		23	762	765	8.2
4SR 25G/75 -F - HYD		34	1134	1137	13.8

MODELO	DN	N. ETAPAS	DIMENSIONES mm		kg
			h2	h	
4SR 33G/5 -F - HYD	2" NPT	3	258	261	2.9
4SR 33G/7 -F - HYD		4	289	292	3.2
4SR 33G/10 -F - HYD		5	320	323	3.5
4SR 33G/15 -F - HYD		6	352	355	3.7
4SR 33G/20 -F - HYD		8	415	418	4.2
4SR 33G/30 -F - HYD		12	566	569	5.3
4SR 33G/50 -F - HYD		19	786	789	8.0
4SR 33G/75 -F - HYD		28	1095	1098	11.4
4SR 33G/100 -F - HYD		36	1418	1421	17.3
4SR 45G/10 -F - HYD		3	258	261	2.9
4SR 45G/15 -F - HYD		4	289	292	3.2
4SR 45G/20 -F - HYD		6	352	355	3.7
4SR 45G/30 -F - HYD		9	446	449	4.5
4SR 45G/50 -F - HYD		14	629	632	6.0
4SR 45G/75 -F - HYD		22	907	910	9.6
4SR 45G/100 -F - HYD		28	1095	1098	11.4



4PD

Motores sumergidos de 4" PEDROLLO

 Uso doméstico

 Uso civil

 Uso industrial



PRESTACIÓN

- Potencia de **0.37 a 7.5 kW**

LÍMITES DE USO

- Temperatura máxima del fluido hasta **+35 °C**
- Profundidad de uso hasta **200 m** bajo el nivel del agua
- Arranques /hora: max **20** con intervalos regulares
- Flujo de enfriamiento mínimo **8 cm/s**
- Funcionamiento continuo **S1**

MOTOR ELÉCTRICO

- Motor eléctrico de 2 polos, 60 Hz ($n \sim 3450 \text{ min}^{-1}$)
- Tensión:
 - monofásica **220 V**
 - trifásica **380 V**
- Aislamiento: clase F
- Protección: IP 68

EN 60034-1
IEC 60034-1
CEI 2-3



EJECUCIÓN Y NORMAS DE SEGURIDAD

- Motores sumergidos en baño de aceite **rebobinables** (aceite atóxico para uso alimenticio)
- **Camisa: acero inox AISI 316**
- **Eje motor: acero inox "DUPLEX"**
- Dimensiones de acople bridas según estandar **NEMA**.
- Completos de cable de alimentación de:
 - **2 m** para potencias de 0.37 a 2.2 kW
 - **3.6 m** para potencias de 3 a 7.5 kW.

CERTIFICACIONES

Empresa con sistema de gestión certificado DNV
ISO 9001: CALIDAD

EJECUCIÓN BAJO PEDIDO

- Otros voltajes

GARANTIA

2 años según nuestras condiciones generales de venta

ÁNODO DE SACRIFICIO

(Suministro bajo pedido – código ASS4PDA01)

- Realizado con una aleación especial de aluminio-zinc "cadmium-free", adecuada para el contacto con agua potable.
- Se aplica fácilmente a la extremidad inferior de los motores 4PD para protegerlos de la corrosión en presencia de corrientes vagues o aguas particularmente agresivas, aumentando notablemente la duración de los componentes del motor.



DATOS DE PRESTACIÓN

Versiones monofásicas

MODELO	Potencia nominal P ₂		Carga axial N	Rev. min ⁻¹	Corriente arranque Corriente nominal	Factor de potencia cos φ	Condensador (VL=450V) μF	h2 mm	Peso kg
	kW	HP							
220 V / 60 Hz									
4PDm / 0.50	0.37	0.50	2000	3450	2.7	0.95	20	331	7.5
4PDm / 0.75	0.55	0.75		3420	2.1	0.94	25	331	7.7
4PDm / 1	0.75	1		3435	2.4	0.94	35	356	8.9
4PDm / 1.5	1.1	1.5		3425	2.5	0.93	40	396	10.6
4PDm / 2	1.5	2		3445	2.6	0.90	60	437	12.6
4PDm / 3	2.2	3		3425	2.9	0.92	75	492	14.9

Versiones trifásicas

MODELO	Potencia nominal P ₂		Carga axial N	Rev. min ⁻¹	Corriente arranque Corriente nominal	Factor de potencia cos φ	h2 mm	Peso kg
	kW	HP						
380 V / 60 Hz								
4PD / 0.50	0.37	0.50	2000	3455	3.4	0.79	331	7.5
4PD / 0.75	0.55	0.75		3450	3.3	0.68	331	7.7
4PD / 1	0.75	1		3460	3.7	0.61	356	8.8
4PD / 1.5	1.1	1.5		3440	3.5	0.72	371	9.4
4PD / 2	1.5	2		3445	3.5	0.76	396	10.6
4PD / 3	2.2	3		3430	3.2	0.73	437	12.5
4PD / 5.5	4	5.5	5000	3440	4.1	0.78	505	16.3
4PD / 7.5	5.5	7.5		3450	4.2	0.80	590	20.1
4PD / 10	7.5	10		3440	4.2	0.81	800	29.5

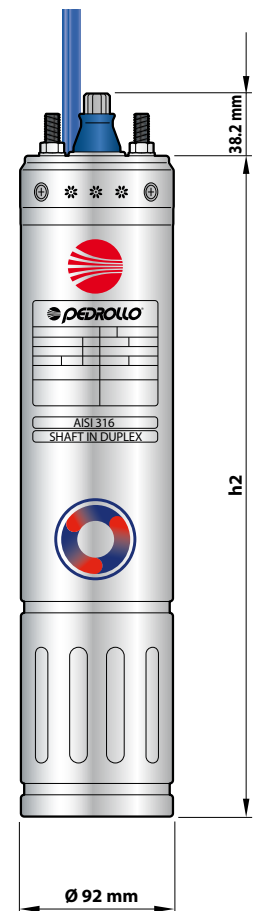

CONSUMO EN AMPERIOS

MODELO	Service Factor	TENSIÓN (monofásica)	
		220 V	
Monofásica		Corriente nominal	Corriente en el Service Factor
4PDm / 0.50	1.6	3.4 A	4.2 A
4PDm / 0.75	1.5	4.7 A	6.8 A
4PDm / 1	1.4	6.3 A	8.1 A
4PDm / 1.5	1.3	8.3 A	10.8 A
4PDm / 2	1.25	10.8 A	13.5 A
4PDm / 3	1.15	15.5 A	16.6 A

MODELO	Service Factor	TENSIÓN (trifásica)			
		220 V		380 V	
Trifásica		Corriente nominal	Corriente en el S. F.	Corriente nominal	Corriente en el S. F.
4PD / 0.50	1.6	2.0 A	2.9 A	1.2 A	1.6 A
4PD / 0.75	1.5	3.2 A	4.1 A	1.9 A	2.3 A
4PD / 1	1.4	4.5 A	5.3 A	2.7 A	3.0 A
4PD / 1.5	1.3	6.7 A	7.4 A	3.9 A	4.3 A
4PD / 2	1.25	6.8 A	8.2 A	4.5 A	5.1 A
4PD / 3	1.15	9.6 A	10.6 A	6.7 A	7.4 A
4PD / 5.5	1.15	16.5 A	18.4 A	9.9 A	11.2 A
4PD / 7.5	1.15	21.9 A	25.1 A	12.9 A	14.2 A
4PD / 10	1.15	28.1 A	31.4 A	16.9 A	18.9 A